

## IMPORTANT: Give to Safety Manager

### Die Flipping Hoist Rings

ALWAYS READ AND UNDERSTAND THE SAFETY AND INSTALLATION INFORMATION. PLEASE FOLLOW THE SAFETY AND INSTALLATION GUIDE WHEN USING HOIST RINGS. CONTACT JERGENS INC. WITH ANY QUESTIONS.

**ATTENTION:** Wrong installed or damaged/defective hoist rings as well as improper use can lead to serious personal injuries or property damage.

#### Safety Information

Jergens Die Flipping hoist rings are designed and rated to be pulled at any angle from 0° to 90° to the bolt axis at the rated load (Fig.4). However, the applied load on a multipoint lift will increase if the horizontal sling angle decreases. So be sure to consider the sling angle when selecting lifting equipment. See illustrations below.

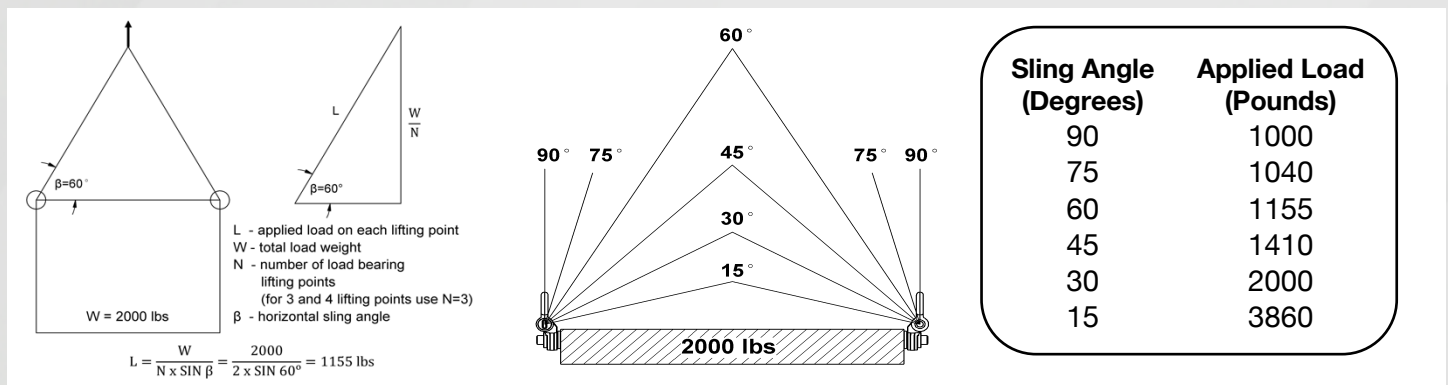

- ALWAYS check hoist ring for free swivel and pivot action before and after installation. Any movement restrictions are the reason to remove the hoist ring from service.
- NEVER use an oversize hook or other oversize lifting device that will pry or tend to deform the shackle (Fig.1).
- Make sure the hoist ring shackle or hardware attached to it does not come in contact with the workpiece or any obstacles during the lift. The shackle must not bind on the edge of the workpiece. Use spreader beam to avoid binding (Fig.2).
- Depending upon the sling angle, the applied load may be more than the weight being lifted i.e., two-point lifting of a 2000 pounds weight with a horizontal sling angle of 30° will result in an applied load of 2000 pounds to each hoist ring! (chart above & Fig.5).
- NEVER exceed rated Load Capacity marked on each hoist ring.
- NEVER reeve slings from one hoist ring to another (Fig.6)
- When lifting, apply force gradually. **DO NOT APPLY SHOCK LOADS.** If shock load occurs, remove all hoist rings used in the application from service for further evaluation.
- To maintain full load capacity use Jergens hoist rings within the specified temperature range only:
  - -20°F(-28°C) to 400°F(204°C)
- Avoid using Die Flipping hoist rings in corrosive area, use Stainless Steel, plated Envirolox (Electroless Nickel) or with other plating hoist rings instead.
- NEVER alter hoist rings.
- All hoist rings shall be inspected per ASME B30.26 by a designated person.



## IMPORTANT: Give to Safety Manager

### WARNING

1. JERGENS HOIST RING COMPONENTS ARE NOT INTERCHANGEABLE WITH OTHER MANUFACTURERS' HOIST RINGS. SUBSTITUTION OF PARTS VOIDS ALL LIABILITIES AND MAY RESULT IN HOIST RING FAILURE AND POSSIBLE INJURY.
2. JERGENS HOIST RING ASSEMBLIES ARE PROOF-TESTED TO 200% OF RATED LOAD CAPACITY. CERTIFICATE OF PROOF TEST ACCOMPANIES PRODUCT IN FINAL PACKAGING.
3. PROPER WARNING LABEL AFFIXED TO EACH HOIST RING.
4. 5:1 STRENGTH FACTOR
5. JERGENS HOIST RINGS ARE HEAT TREATED, MAGNETIC PARTICLE INSPECTED, PROOF LOAD TESTED AND CERTIFIED TO MANUFACTURING SPECIFICATIONS.

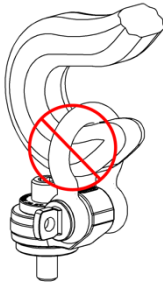

**Fig 1**

**NEVER** use an oversize hook or other lifting device!

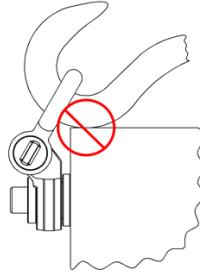

**Fig 2**

The hoist ring components or attached hardware **MUST NOT** bind on anything!

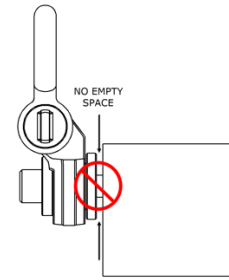

**Fig 3**

**ALWAYS** ensure full thread engagement!

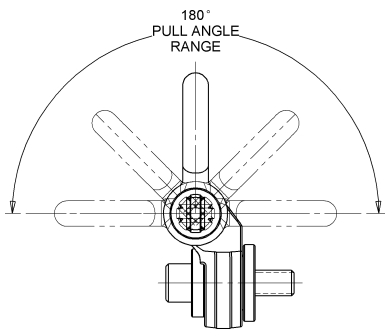

**Fig 4**

Acceptable pulling area, restrictions apply (see Fig.2 and Safety Information above)

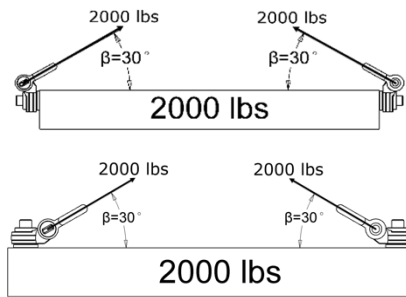

**Fig 5**

Depending upon the sling angle, the applied load may be more than the weight being lifted.

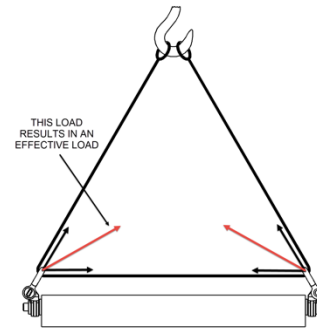

**Fig 6**

Never reeve slings from one hoist ring to another.



## IMPORTANT: Give to Safety Manager

### Installation Information

*Before installation each hoist ring shall be visually inspected by the user and any condition that may result in hazard shall be the reason to remove the hoist ring from service.*

- Select the proper hoist ring style that have suitable characteristics for the type of load, angle of loading, hitch and environment.
- Drill and tap the workpiece so that the hoist ring bolt is installed perpendicular to the surface of the workpiece. Countersink the tapped hole to prevent “swelling” of the top thread when the hoist ring bolt is torqued. The workpiece surface must be flat, providing complete contact for the hoist ring bearing surface. The tapped hole must be deep enough to ensure the hoist ring bolt is fully engaged and there is no empty space between the hoist ring bearing surface and the workpiece surface (Fig.3).
- DO NOT use spacers between the hoist ring bearing surface and the workpiece surface.
- ALWAYS tighten the hoist ring bolt to the torque value marked on each hoist ring (+/-10%) using an adequate torque wrench. DO NOT install/uninstall hoist ring by using an impact wrench.
  - Loosening of the bolt may develop during use. Re-tightening to the required torque, marked on the hoist ring, must be done whenever the bolt loosens.
  - The recommended torque should prevent from self-unscrewing/loosening of the hoist ring bolt when under load and during positioning of the lifted object. However, to make sure an unintended loosening from i.e. vibration or rotation will not occur, if possible, using different locking systems i.e. liquid locking fluids such as Loctite (respect manufacturer specification), locknuts, castle nuts etc. and tighten with the specified torque is recommended. Jergens hoist rings are not intended for applications requiring constant rotation under load.
- The following lengths of thread engagement are recommended:
  - 1.5 times the thread diameter – when installing in steel (if parent material is minimum 80,000 PSI of Ultimate Tensile Strength)
  - 2 times the thread diameter – when installing in aluminum
  - 2.5 times the thread diameter – when installing in light alloys of low strength. Through hole with washer and nut on the opposite side is recommended.
- For through-hole applications, be sure to select nut and washer that are the same quality grade as the hoist ring. Jergens recommends to use:

#### Nut:

ASTM A194/194M (Inch/Metric)	ASTM A563 (Inch)	ASTM A563M (Metric)	ISO 898-2
• Grade 2H	• Grade DH	• Class 10S	• Class 10
• Grade 4	• Grade DH3		• Class 12
• Grade 7			

#### Washer:

ASTM F436/F436M	DIN 6340, ISO 887 (Metric)
•Type 1, Round	

- After installation check the hoist ring to make sure it swivels and pivots freely in all directions.

### Hoist Ring Care and Maintenance

In addition to following a routine maintenance schedule, all hoist rings shall be inspected per ASME B30.26.

- The black oxide finish provides slight lubrication and mild corrosion resistance. However, over time some of the coating may be worn off during normal use.
- To prolong the lifespan of Jergens® hoist rings:
  - Use only as directed in the data sheet.
  - Limit exposure to water or high humidity environment. Dry or wipe off water and foreign chemicals that accumulate on the surface or in the gaps of the product.
  - Lightly coat and lubricate the product with standard machine oil (any grade) and store indoors in a low humidity environment. A rust preventative coating can also be applied.
- Surface rust can be brushed or sanded off. Rust preventative coating can be applied to areas where the black oxide has been removed. For a more corrosion resistant solution, Jergens® does offer Stainless Steel products or products with an Envirolux™ or other protective finishes. The Envirolux™ (electroless nickel) plating also provides surface hardness, lubricity, more effective corrosion protection and is environmentally friendly.



## IMPORTANT: Give to Safety Manager

### Stainless Steel and Plated Hoist Rings

Stainless Steel and plated hoist rings shall also follow a routine maintenance schedule depending on severity of the service environment. Even these products shall not be submerged or exposed to saltwater environment for extended period of time due to an aggressive attack.

- After every use in such environment flush with fresh water, and in case of contact with questionable chemicals clean immediately with a mild automobile detergent.
- Applying light coat of standard machine oil or rust inhibitor after cleaning is also recommended.
- Do not use any abrasive compounds or metal abrasives to clean stainless steel or plated products. If your hardware requires harsh chemicals or abrasive to clean, you need to reconsider your maintenance schedule.
- Never use strong chemical solutions or strong acids that will destroy the hardware. Use radially available car wash or boat wash products to clean stainless steel or plated hardware instead.

*If there are any questions, please contact Jergens Customer Service: 877-440-LIFT (5438) [lifting@jergensinc.com](mailto:lifting@jergensinc.com)*

