

## IMPORTANT: Give to Safety Manager

### Traditional Center Pull Lift-Check™ Hoist Rings

ALWAYS READ AND UNDERSTAND THE SAFETY AND INSTALLATION INFORMATION. PLEASE FOLLOW THE SAFETY AND INSTALLATION GUIDE WHEN USING HOIST RINGS. CONTACT JERGENS INC. WITH ANY QUESTIONS.

**ATTENTION:** Wrong installed or damaged/defective hoist rings as well as improper use can lead to serious personal injuries or property damage.

#### Safety Information

Jergens Center Pull Lift-Check hoist rings are designed and rated to be pulled at any angle from 0° to 90° to the bolt axis at the rated load. However, the applied load on a multipoint lift will increase if the horizontal sling angle decrease. So be sure to consider the sling angle when selecting lifting equipment. See illustration below.

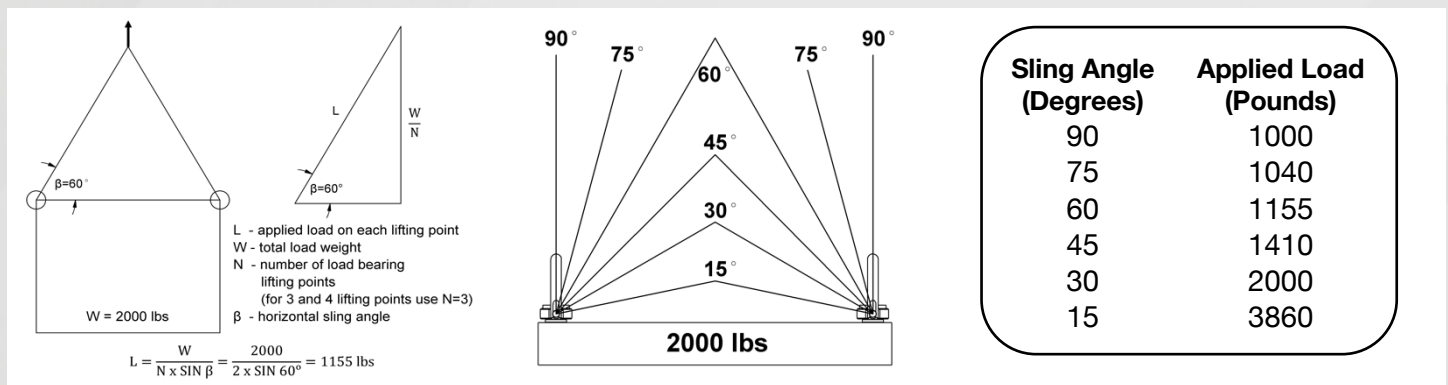

- NEVER use Lift-Check™ hoist ring if the Visual Indicator color appears BLACK before hoist ring is installed!
- ALWAYS check hoist ring for free swivel and pivot action before and after installation. Any movement restrictions are the reason to remove the hoist ring from service.
- NEVER use an oversize hook or other oversize lifting device that will pry or tend to deform the bail/ring (Fig. 1).
- Make sure the hoist ring bail/ring or hardware attached to it does not come in contact with the workpiece or any obstacles during the lift. The bail/ring must not bind on the edge of the workpiece. Use spreader beam to avoid binding (Fig. 2).
- The load applied to the hoist ring shall be centered in the bail/U-shape. Never pull hoist ring bail/U-shaped ring from a side (Fig. 3.)
- Depending upon the sling angle, the applied load may be more than the weight being lifted i.e., two-point lifting of a 2000 pounds weight with a horizontal sling angle of 30° will result in an applied load of 2000 pounds to each hoist ring! (chart above & Fig. 5).
- NEVER exceed rated Load Capacity marked on each hoist ring.
- NEVER reeve slings from one hoist ring to another (Fig. 6)
- When lifting, apply force gradually. **DO NOT APPLY SHOCK LOADS.** If shock load occurs, remove all hoist rings used in the application for further evaluation.
- To maintain full load capacity use Jergens Center-Pull Lift-Check™ hoist rings within the specified temperature range only:
  - -4°F(-20°C) to 168°F(75°C).
- The Visual Indicator MUST NOT BE RELIED ON IF USING THE LIFT-CHECK™ HOIST RING OUTSIDE THESE OPERATING TEMPERATURES.
- Avoid using Center-Pull Lift-Check™ hoist rings in corrosive area, use Stainless Steel, plated Envirolux (Electroless Nickel) or with other plating, hoist rings instead.
- NEVER alter hoist rings.
- All hoist rings shall be inspected per ASME B30.26 by a designated person.



## IMPORTANT: Give to Safety Manager

### WARNING

1. JERGENS HOIST RING COMPONENTS ARE NOT INTERCHANGEABLE WITH OTHER MANUFACTURERS' HOIST RINGS. SUBSTITUTION OF PARTS VOIDS ALL LIABILITIES AND MAY RESULT IN HOIST RING FAILURE AND POSSIBLE INJURY.
2. JERGENS HOIST RING ASSEMBLIES ARE PROOF-TESTED TO 200% OF RATED LOAD CAPACITY. CERTIFICATE OF PROOF TEST ACCOMPANIES PRODUCT IN FINAL PACKAGING.
3. PROPER WARNING LABEL AFFIXED TO EACH HOIST RING.
4. 5:1 STRENGTH FACTOR
5. JERGENS HOIST RINGS ARE HEAT TREATED, MAGNETIC PARTICLE INSPECTED, PROOF LOAD TESTED AND CERTIFIED TO MANUFACTURING SPECIFICATIONS.

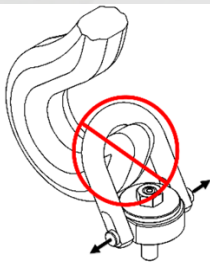

**Fig 1**

**NEVER** use an oversize hook or other lifting device!

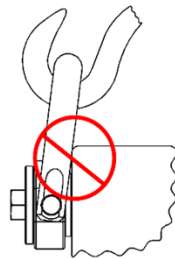

**Fig 2**

The hoist ring components or attached hardware **MUST NOT** bind on anything!

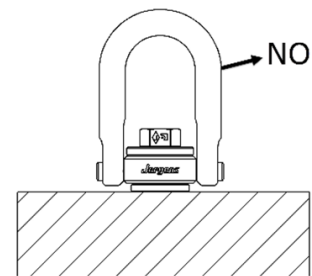

**Fig 3**

**NEVER** pull ring/bail from a side!  
The load applied to the hoist ring shall be centered in the bail to avoid side loading

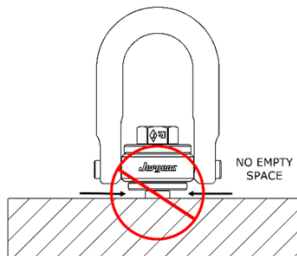

**Fig 4**

**ALWAYS** ensure full thread engagement when installing hoist rings!

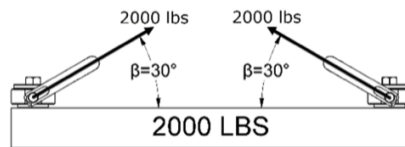

**Fig 5**

Depending upon the sling angle, the applied load may be more than the weight being lifted.

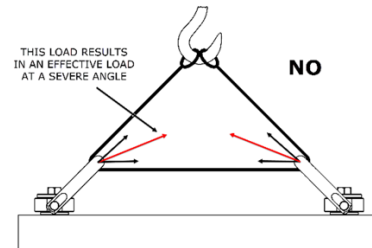

**Fig 6**

Never reeve slings from one hoist ring to another.



## IMPORTANT: Give to Safety Manager

### Installation Information for Lift-Check™ Hoist Ring (Hoist Ring with Visual Indicator)

*Before installation each hoist ring shall be visually inspected by the user and any condition that may result in hazard shall be the reason to remove the hoist ring from service.*

- Before use, read and understand “Lift-Check™ Hoist Ring Visual Indication Information” in the data sheet.
- Select the proper hoist ring style that have suitable characteristics for the type of load, angle of loading, hitch and environment.
- Drill and tap the workpiece so that the hoist ring bolt is installed perpendicular to the surface of the workpiece. Countersink the tapped hole to prevent “swelling” of the top thread when the hoist ring bolt is torqued. The workpiece surface must be flat, providing complete contact for the hoist ring bearing surface. The tapped hole must be deep enough to ensure the hoist ring bolt is fully engaged and there is no empty space between the hoist ring bearing surface and the workpiece surface (Fig. 4) **otherwise the color of the indicator will never change to black indicating there is no preload in the bolt.**
- Before any load is applied to the hoist ring the bolt **MUST** be tightened until the Visual Indicator color changes from red to black or to the recommended minimum torque value. Keep in mind the indicator turning black is a more accurate representation of proper bolt tension than the reading of the torque wrench due to frictional variances while tightening.
  - Tightening the bolt until the color of the indicator is black should prevent from self-unscrewing/loosening of the hoist ring bolt when under load and during positioning of the lifted object. However, to make sure an unintended loosening from i.e. vibration or rotation will not occur, if possible, using different locking systems i.e. liquid locking fluids such as Loctite (respect manufacturer specification), locknuts, castle nuts etc. and tighten until the color of the indicator appears black is recommended. Jergens hoist rings are not intended for applications requiring constant rotation under load.
  - Bolt loosening may develop during use. Periodic review of the indicator should be performed when the hoist ring is installed and no load is applied to it. If the color of the indicator remains completely black the bolt is still correctly preloaded otherwise the bolt must be re-tightened.
- For permanent lifts or in instances where bolts may have been overloaded, Jergens Inc. recommends verifying the bolt by loosening. If the color of the indicator returns to red, the indicator and bolt are adequate for use (unless in an abusive environment application). The Hoist Ring itself should be inspected per ASTM B30.26 to insure a proper lift. If the color of the indicator does not return to red, the bolt has been overloaded and the hoist ring must be immediately removed from service.
- DO NOT use spacers between the hoist ring bearing surface and the workpiece surface.
- The following lengths of thread engagement are recommended:
  - 1.5 times the thread diameter – when installing in steel (if parent material is minimum 80,000 PSI of Ultimate Tensile Strength)
  - 2 times the thread diameter – when installing in aluminum
  - 2.5 times the thread diameter – when installing in light alloys of low strength. Through hole with washer and nut on the opposite side is recommended.
- For through-hole applications, be sure to select nut and washer that are the same quality grade as the hoist ring. Jergens recommends to use:

#### Nut:

ASTM A194/194M (Inch/Metric)	ASTM A563 (Inch)	ASTM A563M (Metric)	ISO 898-2
• Grade 2H	• Grade DH	• Class 10S	• Class 10
• Grade 4	• Grade DH3		• Class 12
• Grade 7			

#### Washer:

ASTM F436/F436M	DIN 6340, ISO 887 (Metric)
• Type 1, Round	

- After installation check the hoist ring to make sure it swivels and pivots freely in all directions.

### Hoist Ring Care and Maintenance

In addition to following a routine maintenance schedule, all hoist rings shall be inspected per ASME B30.26.

- The black oxide finish provides slight lubrication and mild corrosion resistance. However, over time some of the coating may be worn off during normal use.
- To prolong the lifespan of Jergens® hoist rings:
  - Use only as directed in the data sheet.
  - Limit exposure to water or high humidity environment. Dry or wipe off water and foreign chemicals that accumulate on the surface or in the gaps of the product.



## IMPORTANT: Give to Safety Manager

- Lightly coat and lubricate the product with standard machine oil (any grade) and store indoors in a low humidity environment. A rust preventative coating can also be applied.
- Surface rust can be brushed or sanded off (except indicator area). Rust preventative coating can be applied to areas where the black oxide has been removed. For a more corrosion resistant solution, Jergens® does offer Stainless Steel products or products with an Envirolox™ or other protective finishes. The Envirolox™ (electroless nickel) plating also provides surface hardness, lubricity, more effective corrosion protection and is environmentally friendly.

### Lift-Check™ Hoist Ring Visual Indication Information

#### 1. Preloading by Visual Indicator

The traditional method for tightening fasteners is to turn the head or nut using a torque measuring tool such as a torque wrench until a “torque spec” is reached. The tool may be very accurate, but measuring torque only measures how difficult it is to turn the head or nut. It provides little information on the force that is actually holding the joint together – tension.

On the other hand, direct tension indicators respond to fastener tension ONLY, ignoring torque inputs, providing a true measure of joint tightness. Tension, or clamp force, is the only factor that ensures that a bolted joint is “tight”.

Tensioning the Lift-Check™ hoist ring bolt by visual reference should be done carefully. Before any load is applied to the hoist ring, for proper loading the Lift-Check™ indicator must be red before tightening and then change to black to indicate proper tension. See Pictures below. There must be sufficient light illuminating the indicator to enable the operator to observe color changes occurring as the bolt is tightened. For best results a fluorescent full spectrum light source or natural light is recommended. If this is not available LED light source with an output of 87 Lumens or less may be used. The light source should be positioned a minimum of two feet away from the indicator. Use of an incandescent light source is not recommended.



**RED INDICATES  
LOOSE**



**BLACK INDICATES  
TIGHT**

A box-end wrench is the preferred method of tightening the bolt head. It is best to tighten the fastener slowly by applying a smooth even pull. The bolt should be tightened until the indicator color changes from red to BLACK. This is the point where the Design Tension has been reached and where further tightening will cause very little color change. BE CAUTIOUS not to over tighten the Lift-Check™ hoist ring bolt significantly past the point when the color turns to black, potentially exceeding the Proof Load, which may cause a loss of calibration or damage the visual indicator.

#### 2. Preloading by Torque Control

Using torque control for installation, the torque-tension relationship should be established by carefully applying the recommended torque value in a steady even pull with a calibrated torque wrench. Remove the torque wrench and check if the indicator color is black. If the indicator is not fully black (TIGHT), increase the installation torque until it is properly preloaded. Keep in mind the indicator turning black is a more accurate representation of proper bolt tension than the reading of the torque wrench due to frictional variances while tightening.

#### 3. Lift-Check Hoist Ring Bolt and Joint Preparation

Lubricating the bolt threads and bearing surfaces (on bolt and washer) with a suitable grease or thread lubricant will help to ease the force required to set the Design Tension by means of the visual indicator. It will also prevent galling damage to the bolt threads.

#### 4. Proper Care and Handling of the Bolt

Proper care should be taken to protect the indicator from direct impact during handling and use. The indicator is a precision measuring device that is calibrated and under proper use can remain accurate for the life of the Lift-Check™ hoist ring. A cloth dampened with water can be used to wipe away contaminants and applying a light coat of oil is acceptable. Contact of the indicator with harsh solvents or cleaners should be avoided.

***If there are any questions, please contact Jergens Customer Service: 877-440-LIFT (5438) [lifting@jergensinc.com](mailto:lifting@jergensinc.com)***

